



Improving the surface hardness of subsoil plow chisel using water jet peening

S. Sujita

Jurusan Teknik Mesin, Fakultas Teknik, Universitas Mataram, Jl. Majapahit no. 62, Mataram, NTB, 83125, Indonesia. HP. 08175781386
E-mail: sujita@unram.ac.id

ARTICLE INFO

ABSTRACT

Article History:

Received 24 January 2019

Accepted 05 March 2019

Available online 1 July 2019

Keywords:

Subsoil plow chisel

Waterjet peening

Surface hardness number

Austenitic stainless steel 301



This study discusses the effects of pressure in waterjet peening (WJP) of subsoil plow chise. It was made from austenitic stainless steel 301 JIS standard S30100. Analysis of surface integrity and change of surface hardness number is used to evaluate the performance of various parameters in the WJP process. The article summarizes information about austenitic stainless steel physically-mechanical of subsoil plow chisel that is most useful for soil tillage. The subsoil chisel was given surface treatment WJP process with a variation of pressure and time. The physical properties of subsoil plow chisel from various pressure and time of WJP are analyzed. The findings of this study indicated that surface treatment with waterjet peening could increase the surface hardness number and the hardening layer from austenitic stainless steel 301 (material of subsoil plow chisel). Treats the surface with WJP pressure 250 MPa and time 3 hours results in a higher increase in surface hardness number up to 41% and 151% greater than the raw material respectively. Also, a deeper hardening layer to depth 250 and 500 μm each produced. Next, the cross-sectional micro structure shows the density is higher than the slip band in the defective grain of specimens that have undergone the WJP process at the time and higher pressure. However, the number of slip bands in grain defects decreases with the pressure drop.

Dinamika Teknik Mesin, Vol. 9, No. 2 Juli 2019, p. ISSN: 2088-088X, e. ISSN: 2502-1729

1. INTRODUCTION

Surface heat treatment of steel components is one of the primary aspects of mechanical engineering. Based on the chemical composition of the given material, it is possible to achieve optimal mechanical properties and durability of replaceable parts, Stachowik et al. (2005). Depending on the variety and quantity of machinery in use in an agricultural enterprise, appropriate heat treatment can significantly reduce operating costs. Mechanical engineers of agricultural machines have always been seeking techniques increasing the efficiency of tillage tools, saving energy and decreasing expenses of

tillage operations Mouazcn et al. (2007). Although the wear of tillage instruments have been introduced as the main effective factor regarding energy consumption in agricultural sector, only a few studies have been done on the hardness number of chisel subsoil plow dealing with soil in agricultural sector (Karoobonyanan et al., 2007., Oka et al., 2007., Kong et al., 2010). Studies on wear indicate that damages resulting from the wear of instruments and engineering parts have been calculated to be 1%, 2.5%, and 1.5% of the gross national production in England, Germany, and the United States, respectively Ju and Han (2009). Studies carried out in Turkey indicate that the wear rate is (90 – 210 grams) in moldboard plow blades, (60 - 120 grams) in cultivator sweeps, and (23 – 40 grams) in chisel plow blades per hectare, Bayhan et al. (2006).

A significant number of researchers have investigated the effect of the uses steel alloys, cast iron with hard chrome covering or nickel and also surface coverings such as aluminum, tungsten carbide, cobalt, chrome as well as nitridation to protect metals against the wear (Horvat et al., 2008; Daoming, et al., 2009; Yazici, 2011) used three types of rotary tiller blades in order to determine the effect of hardened covering of blade Yazici des and found that blades with aluminum covering cannot provide enough resistance on blade edges, whereas blades with cobalt and tungsten coverings have enough resistance around 43 times more than the resistance created by the blades with aluminum covering.

Currently the technology and applications of high pressure waterjet have been studied for decades. Use of waterjet technology such as machines, surface preparation, cleaning, coating removal and surface treatment. In the machining process, a high-pressure waterjet is used to cut workpieces, drilling, grinding, with a addition of abrasive particles, the machining capability of waterjet is significantly improved. However, processing parameters and different material properties must be carefully assessed to produce the desired cutting quality. Using water only at relatively low pressure, cleaning of the surface from dirt or mantle can be achieved, Cui et al. (2007). High pressure waterjet is also used successfully to process coal into powder Chillman et al. (2007).

The WJP process provides many advantages, especially for producing clean and smooth surfaces and not causing thermal effect. If the waterjet nozzles are attached to the robot manipulator, it is possible to treat components with complex geometry. Much research has been done to study potential and related applications science. Chillman et al. (2006) explores the effects of high pressure WJP at 600 MPa at final surface and integrity from titanium alloys (Ti - 6Al - 4V). They found that WJP at 600 MPa induces a plastic deformation to greater depths in the subsurface layer and also a higher degree of plastic deformation. Grinspan and Gnanamoorthy (2016), changed water with oil in the aluminum alloy peening process where residual stress depth is considered more than 250 μm below the surface.

This study aims at examining the surface hardness of subsoil plow chisel after surface treatment WJP with various pressures. Besides, determining the optimal pressures of WJP to produce the best mechanical properties of subsoil plow chisel

2. EXPERIMENTAL PROCEDURES

2.1 Materials

This study focused on austenitic stainless steel 301 (JIS S30100), a structural steel used widely for subsoil plow chisel parts where hardened case is desired for increase hardness number and wear resistance. The austenitic steel 301 is commonly used for stainless applications because of its good formability at room temperature. Shen et al. (2010). Stainless steel 301 is also used in chemical processing equipment and heat exchangers for the food, milk, beverage and orthopedic applications Karabelchtchikova and Rivero (2005).

The chemical composition of austenitic steel 301 is given in Table 1. For this study, specimens were cut from a long bar subsoil plow chisel parts. The dimension of the specimen is given in figure 2. Both surfaces of specimens were CNC milled followed by surface grinding to minimize previous surface roughness. The surfaces of the received specimens were already polished and film coated with an average surface roughness Ra of 0.15 μm . The schematic set up of the WJP process is shown in figure 1.

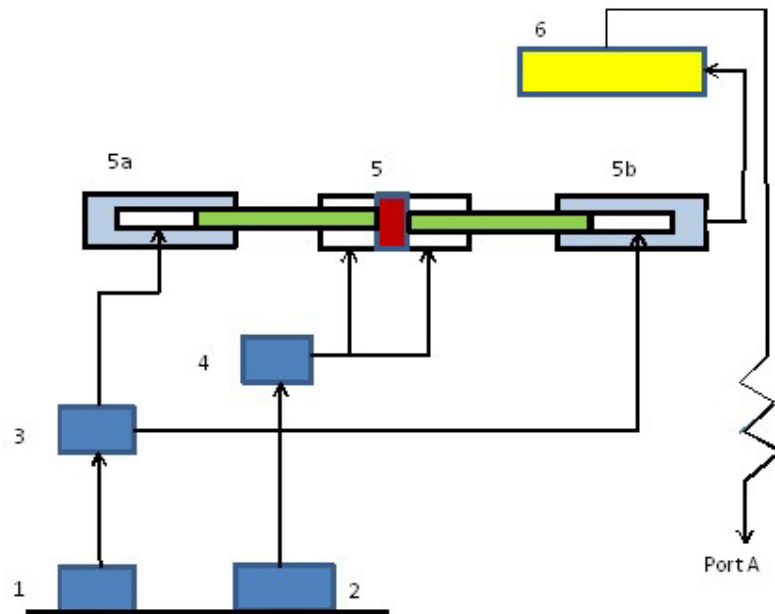

Figure 1. Aparatus WJP diagram. 1. LP booster, 2. hydraulic drive, 3. additive mixer, 4. direction control, 5. intensifier, 5a. LP intensifier, 5b. HP intensifier, 6. accumulator,



Figure 2. Dimension of the specimen

Table 1. Chemical composition of austenitic stainless steel 301 (JIS S30100)

Unsur	%wt
C	0.08
N	0.4
Cr	16.6
Ni	6.8
Mo	0.2
Mn	1.0
Si	0.45
S	0.001

P	0.03
Cu	0.3

2.2. Experimental Procedures

The specimens were treated with waterjet peening at various pressure ranging from 150 MPa, 200 MPa and 250 MPa with a length of processing time ranging from 1, 2, and 3 hours. Each specimen is carefully clamped on the machine table. Distance between nozzle and specimen 2 mm. UHDE brand waterjet pumps can produces pressures of up to 6,000 sticks. The nozzle has a diameter of 0.3 mm made of stainless steel, produced by Quick-Ohm Küpper & Co GmbH. Nozzle. The resulting surface width is about 0.8 mm. The process is carried out without using an abrasive so that it does not increase the roughness of the specimens release.

Surface hardness number was measured on polished cross-sections of specimens using a computer controlled Buehler OmniMet MHT hardness tester. The Vickers hardness (HV) was obtained as a function of depth with 10 gf load over a 15-s indentation period. An average of at least four hardness data was recorded. Microstructural analysis was conducted using the scanning electron microscope (SEM) Philips-XL 40. Secondary electron image was employed for the characterization of both peened surfaces and subsurfaces.

3. RESULTS AND DISCUSSION

3.1 Surface hardness number

The result of surface hardness number test for raw materials were 220 Kg/mm². The effect of pressure on surface hardness number as a function of distance from the surface at waterjet peening time 1, 2, and 3 hours is shown in figure.4 – figure.6. The trend that occurs in surface hardness number decreases gradually from the surface. In addition, higher hardness gradients are found in specimens treated with higher pressure and time. The Figureure shows that there is an increase in average miniimum surface hardness number of about 27%, 54%, and 70% for pressures of 150 MPa and waterjet time 1, 2, 3 hour respectively, and there is an increase in average maximum hardness of about 41%, 125%, and 151% for pressures of 250 MPa and waterjet time 1, 2, 3 hour respectively as compared with the raw material. Interestingly, in this case, the depth of strengthened layer is extended up to 200 µm. The specimen treated with the highest pressure of 250 MPa shows a higher depth of up to 500 µm. This phenomenon shows that the high pressure raises the kinetic energy of a larger water molecule, which increases hardness, according to the results of the research Azhari et al. (2012), show figure 7.

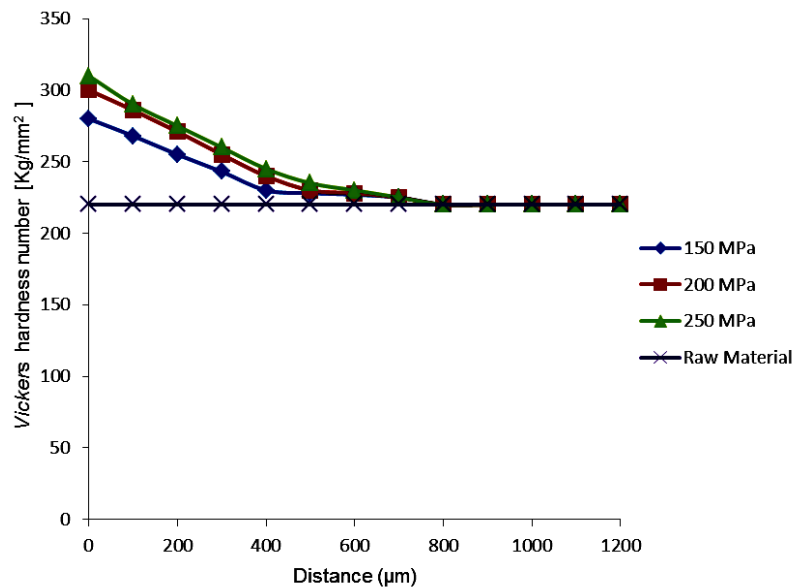

Figure 4. Surface hardness number of specimens at waterjet peening time 1 hours .

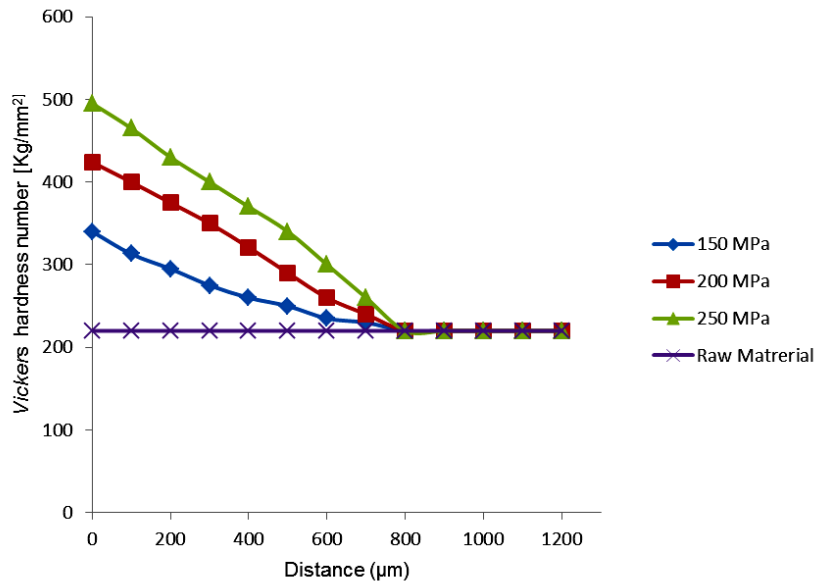

Figure 5. Surface hardness number of specimens at waterjet peening time 2 hours

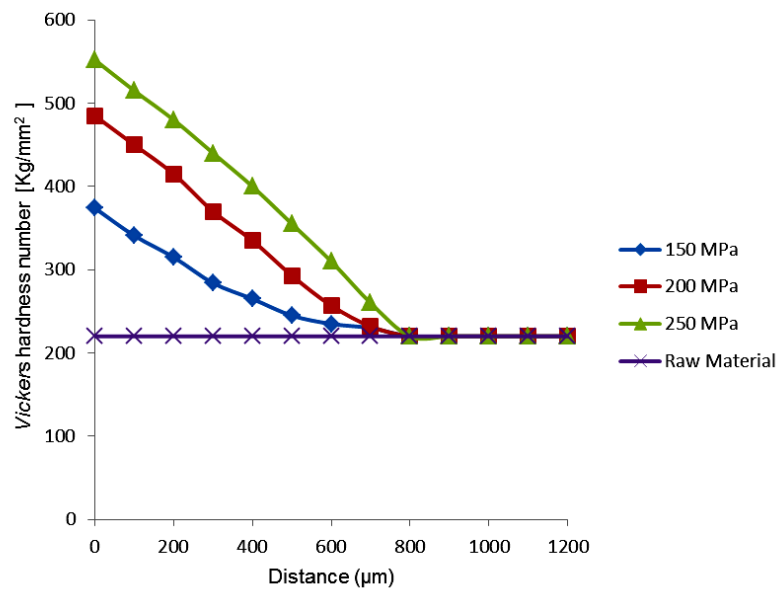

Figure 6. Surface hardness number of specimens at waterjet peening time 3 hours

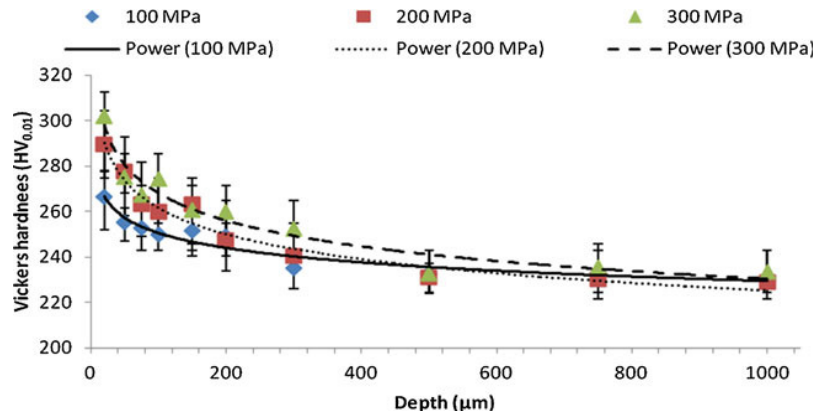

Figure 7. Surface hardness number of austenitic stainless steel 304 after waterjet peening treated

3.2 Thickness of hardening layer

The thickness of the hardening layer can be shown by the results of the hardness number test. It is indicated by the position where the magnitude of the hardness number does not change. Through interpolation of hardness test results, then suspected effective thickness of the hardening layer of pressure WJP 150, 200, 250 MPa were 700 µm, 750 µm, and 800 µm, respectively. Increased hardness of the hardening layer occurs due to structural changes into martensite due to rapid cooling of high temperatures (austenite temperature) to room temperature. Martensite is a very hard structure where the carbon previously in the solid solution in the austenite forms a solution in a new phase, but sometimes there is a small amount of unreformed austenite to form martensite, called retained austenite. Specimens with retained austenite of 32% and 35% in the hardening layer showed relatively high hardness.

3.3 Microstructure of hardening layer

Results from microstructural observation of hardening layer for time 1, 2, and 3 hours at pressure 150, 200, 250 WJP process is given in figure 7, 8, and 9. The microstructures show a similar pattern where slip bands can be clearly seen in the deformed grains especially near the eroded surface as shown in the top insets of figure 7. However, some slip bands still can be seen in the deformed grains away from the surface in the specimen treated with the lowest time as shown in the figure 7. This is to confirm the earlier hardness profile analysis where the hardness gradient is extended up to 250–350 µm for the specimen treated with the lowest feedrate. In contrast, there is an absence of slipbands in the grains away from the surface in the specimens treated with time WJP 2, 3 hours as illustrated in figure 8 and figure 9 respectively. Again, this shows that the deformation of grains is limited up to 100 µm close to the surface as discussed above where the depth of hardening layers for those specimens is about 100 µm. Overall, this is in agreement with Ju and Han (2000) in water cavitation peening (WCP) of pure titanium where they found the density and quantity of the deformed grains increase gradually with increase WCP duration and decrease gradually with increase layer depth from the treated surface. It is to note that higher WJP time implies a smaller impingement duration of the waterjet on the same point of the specimen. Therefore less deformed grains are found in the specimens treated with higher feedrates. Figure 8 shows the subsurface morphologies of peened samples for the WJP time 2 hour. Cross-sectional microstructures of all samples indicate that the substrate experience a certain degree of plastic deformation even up to a depth of 250 µm as shown in the bottom insets of figure 8. Generally, this is in agreement with the hardness gradient analysis above which shows the depth of hardening layer is extended up to 200 µm. Amounts of slip bands in the deformed grains are more abundant and severe in the specimen treated with the higher pressures as illustrated in figure 9. From figure 9 is given that ferrite (light-colored and white) and martensite (dark and black) are larger than carbides. The carbide will enlarge in case of surface treatment of the workpiece (austenitic stainless steel 301). At a pressure of 250 MPa of grain will be deformed over a depth of 250 µm. Even, as shown in figure 14, the hardening layer depth is extended to 500 µm in specimens treated with WJP again, this is the kinetic energy of water molecules is higher. Pressure induces a higher amount of compressive pressure hence plastic changes the shape of more grains and greater depth.

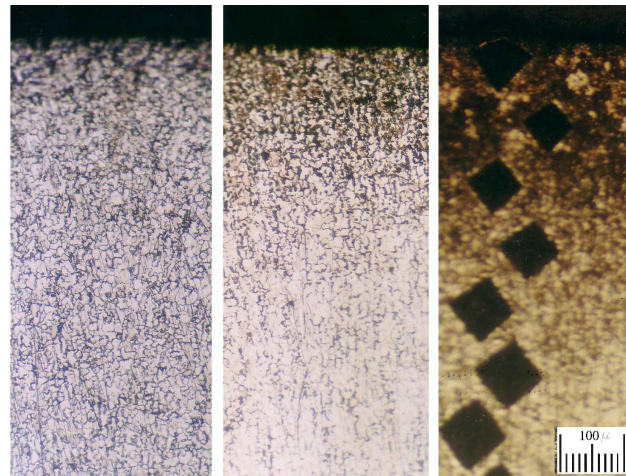

(a.) (b.) (c)

Figure 7. Waterjet peening process for time 1 hours at pressure : a.150 MPa, b. 200 MPa, c.250 MPa

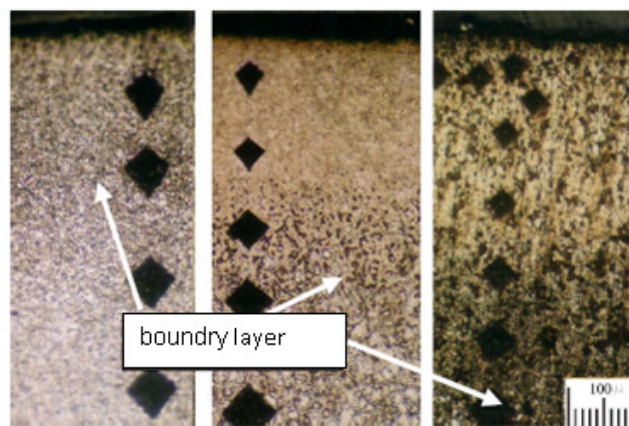

(a.) (b.) (c)

Figure 8. Waterjet peening process for time 2 hours at pressure : a. 150, MPa, b. 200 MPa, c. 250 MPa

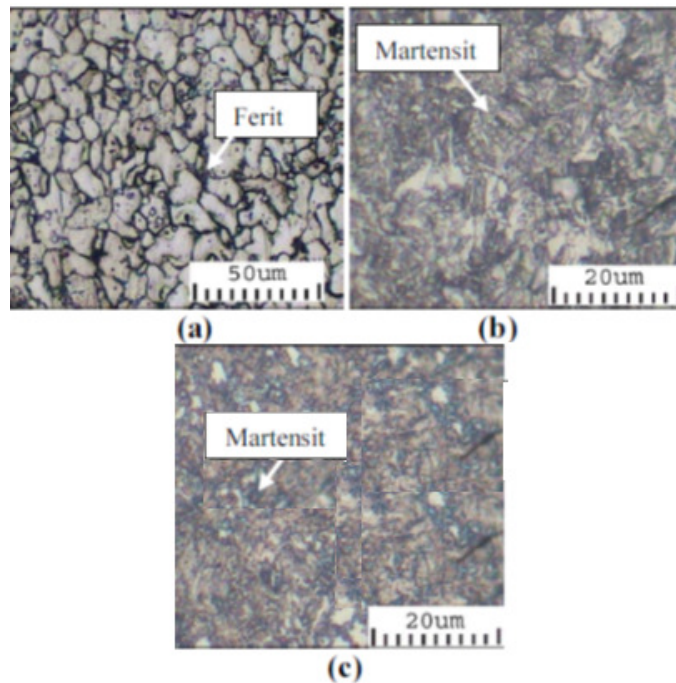

Figure 9. Waterjet peening process for time 3 hours at pressure : a. 150, MPa, b. 200 MPa, c. 250 MPa

4. CONCLUSION

The findings of this study indicated that surface treatment with waterjet peening could increase the surface hardness number and the hardening layer from austenit 301 stainless steel (material of subsoil plow chisel). Based on analysis of combined surface and subsurface Integrity characteristics, conclusions about the effects of pressure and time on WJP the process of austenit 301 stainless steel can be described as follows: Treats the surface with WJP pressure 250 MPa and time 3 hours results in a higher increase in surface hardness number up to 41% and 151% greater than the raw material, respectively. Also, a deeper hardening layer to depth 250 and 500 µm each product. Next, the cross-sectional micro structure shows the density is higher than the slip band in the defective grain of specimens that have undergone the WJP process at the time and higher pressure. However, the number of slip bands in grain defects decreases with the pressure drop.

REFERENCES

- Azhari A., Schindler C., Eberhard K., Patrick G., 2012, Improving surface hardness of austenitic stainless steel using waterjet peening process, *International Journal Advanced Manufacturing Technology*, 63, 1035–1046.
- Bayhan Y., 2006, Reduction of wear via hardfacing of chisel ploughshare, *Tribology International*, 39, 570-574.
- Cui L., Gong W., Jiang H., 2007, A novel process for preparation of ultra-clean micronized coal by high pressure water jet comminution technique, *Fuel*, 86, 750–757.
- Chillman A., Ramulu M., Hashish M., 2007, Waterjet peening and surface preparation at 600 MPa: a preliminary experimental study, *Journal Fluids Engineering*, 129, 485–490.
- Daoming G., Jie C., 2006, ANFIS for high-pressure waterjet cleaning prediction *Surface Coating Technoogy*, 201, 1629–1634.
- Grinspan A.S., Gnanamoorthy R., 2006, A novel surface modification technique for the introduction of compressive residual stress and preliminary studies on Al alloy AA6063, *Surface Coating Technoogy*, 20, 1768–1775.

- Horvat Z., Filipovic D., Kosutic S., 2008, Reduction of mouldboard plough share wear by a combination technique of hardfacing, *Tribology International*, 41, 778-782.
- Ju D.Y., Han B., 2009, Investigation of water cavitation peening induced microstructures in the near-surface layer of pure titanium, *Journal Materials Process Technology*, 4789–4794.
- Kong M.C., Axinte D., Voice W., 2010, Aspects of material removal mechanism in plain waterjet milling on gamma titanium aluminide, *Journal Materials Process Technology*, 210, 573–584.
- Karoonboonyanan S., Salokhe V., Niranatlumpong P., 2007, Wear resistance of thermally sprayed rotary tiller blades, *Wear*, 263, 604-608.
- Karabelchtchikova O., Rivero I.V. 2005, Variability of residual stresses and superposition effect in multipass grinding of highcarbon high-chromium steel, *J Mater Eng Perform*, 14, 50–60.
- Mouazcn A.M., Smoldcrs S., Mcrcsa F., 2007, Improving animal drawn tillage system in ethiopian highlands, *Soil and Tillage Research*, 95, 218-23.
- Oka Y.I., Mihara S., Miyata H., 2007, Effective parameters for erosion caused by water droplet impingement and applications to surface treatment technology. *Wear*, 263, 386–394.
- Shen L., Wang L., Wang Y., 2010, Plasma nitriding of AISI 304 austenitic stainless steel with pre-shot peening, *Surface Coating Technoogy*, 204, 3222–3227.
- Yazici A., 2006, Investigation of the reduction of mouldboard ploughshare wear through hot stamping and hardfacing processes, *Turk J Agric For*, 35, 461-468.